

Model 157T

Differential Pressure Transmitters



Based on silicon capacitive technology, 157T differential pressure transmitters are made from BCM 157M silicon capacitive differential pressure modules. Featuring a full stainless steel housing, 316L stainless steel isolating diaphragm and standard assembly ports, 157T differential pressure transmitters are suitable for rugged industrial applications.

The measuring differential pressure range of 157T transmitters spans from 0~60 mbar to 0~50 bar. The output signal is 4~20 mA with HART protocol. These transmitters are also equipped with a 4½ digits LCD display. 157T transmitters can operate under a system (line or static) pressure of 100 bar with low system pressure effect down to 0.1%fso (fso = full scale output). The measuring accuracy of these transmitters is up to 0.1%fso.

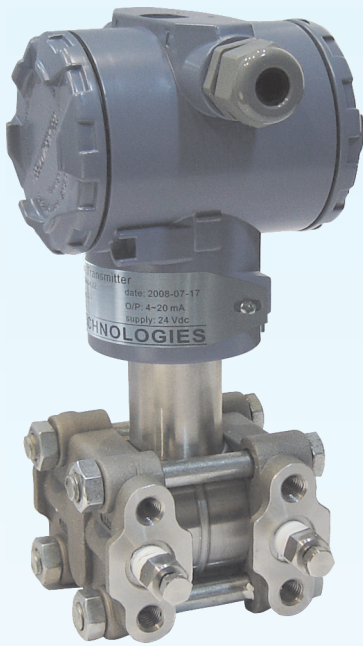

Features:

- pressure ranges: 0~60 mbar, ..., 0~5 bar
- system pressure: 32 bar, 100 bar
- output signal: 4~20 mA with HART protocol + 4½ digits display
- accuracy: 0.1%fso, 0.2 %fso (standard), 0.5 %fso
- materials: 316L (isolating diaphragm), option: Hastelloy-C, Monel 316 SS (flanges)
- operating temperature ranges: -40 ~ +85°C
- protection class: IP 66

Dimensions:

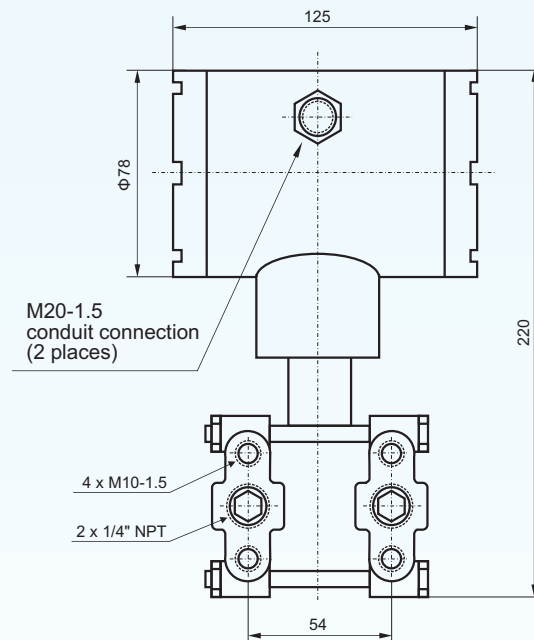

BCM SENSOR TECHNOLOGIES BVBA

Model 157T

Differential Pressure Transmitters



Specifications:

parameters	units	specifications	
pressure media		gases, oils or dilute liquids which are compatible to the diaphragm and flange materials	
pressure ranges	mbar	0~60	0~320, 0~1300, 0~5000
pressure type		Differential (D)	
overload pressure	bar	32	100
system pressure	bar	32	100
system pressure effect		±0.1%FSO@32 bar;	±0.1%FSO@100 bar, ±0.25%FSO@100bar (standard)
power supply	Vdc	24 (recommended), 12, ..., 32	
output signal		4~20 mA with HART protocol	
accuracy	%FSO	± 0.2 (standard), ± 0.5	± 0.1, ± 0.2 (standard), ± 0.5
long-term stability	%FSO/year	± 0.1; ± 0.2 (standard)	
life time	cycle	10 ⁸	
response time	ms	<2	
load resistance	Ω	250~1000	
storage temperature range	°C	-40 ~ +90	
operating temperature range	°C	-40 ~ +85	
compensated temperature range	°C	0 ~ +70	
temperature coefficient of SPAN	%FSO/°C	± 0.01, ± 0.025 (standard)	± 0.005, ± 0.01(standard)
temperature coefficient of ZERO	%FSO/°C	± 0.01, ± 0.025 (standard)	± 0.005, ± 0.01(standard)
process connection	thread	1/4" NPT (female)	
electrical connection	inner thread	M20x1.5 (standard), 1/2 NPT	
materials	membrane	316L SS (standard), option: hastelloy-C, monel	
	flange	316 SS	
	housing for electronics	aluminum alloy	
environment protection	IP rating	IP 66	
display meter		4½ digits LCD display	
net weight	gram	4000	

The listed specifications are subject to change without prior notice.

How to order: model-range-system pressure & effect-output-accuracy-process connection-electrical connection
- other customized requests

ordering code example: 157T - 0/60 mbar - 32 bar, 1 %fso - 4/20mA with HART - 0.25%fso - 1/4 NPT - M20x1.5



BCM SENSOR TECHNOLOGIES BVBA

ISO9001 Certified Company

Industriepark Zone 4, Brechtsebaan 2
B-2900 Schoten - Antwerpen, BELGIUM

Tel.: +32-3-238 6469
Fax: +32-3-238 4171

website: www.bcmsensor.com
email: sales@bcmsensor.com