

Model 1661(I) Single Point Load Cells

Features

- parallel bending beam
- capacity: 2, ..., 30 kg
- accuracy: 0.02 %fs
- recommended platform size: 350 X 350 mm
- aluminum construction with parallel beam
- surface anodized

Applications

- retail scales
- bench scales
- counting scales



Description

The "single point" load cells are made of parallel bending beam working principle. Only one unit is sufficient to build up a scale. These load cells are moment insensitive. That is, when installed in a platform scale, it reads the same regardless of the position of the load applied to the upper platform.

Model 1661(I) load cells are designed to this "single point" type and are manufactured from high quality aluminum alloy of aviation standard. 1661(I) load cells can be used to measure loads ranging from 2 kg to 30 kg with the measuring accuracy of 0.02%fs (fs = full scale).

1661(I) load cells are widely used to manufacture retail, bench, and counting scales.

Dimensions

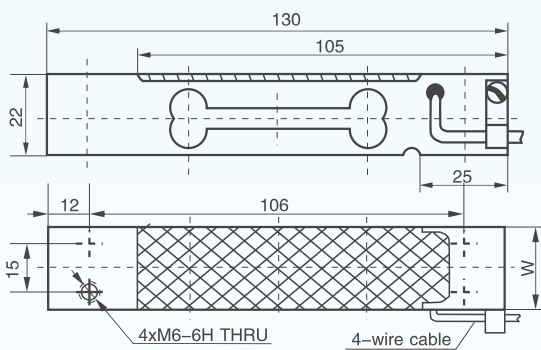

Capacity (kg)	3, 5	10-30
Size (mm)	3, 5	10-30
W	25.4	30

Electrical connection

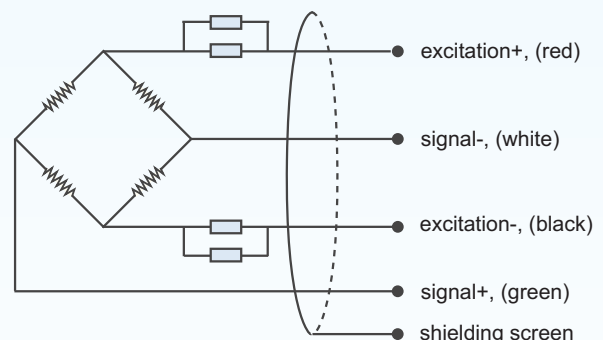

Model 1661(I) Single Point Load Cells



Technical Data

parameters	units	specifications
capacity	kg	2, 3, 5, 7, 10, 20, 30
safe load limit	%fs	120
ultimate overload	%fs	150
output sensitivity at fs	mV/V	2.0 ± 0.2
zero unbalance	%fso	± 1
non-linearity	%fs	± 0.02
hysteresis	%fs	± 0.02
repeatability	%fs	± 0.02
creep error (30 min.)	%fs	± 0.02
excitation (supply voltage)	Vdc	5, ..., 10
max. excitation voltage	Vdc	15
input resistance	Ω	410 ± 10
output resistance	Ω	350 ± 10
insulation resistance	MΩ	≥ 5000@50 Vdc
storage temp. range	°C	-35 ~ +80
operating temp. range	°C	-35 ~ +65
compensated temp. range	°C	-10 ~ +40
temp. coefficient of sensitivity	%fs/°C	± 0.002
temp. coefficient of zero	%fs/°C	± 0.003
load cell body material		aluminum alloy
sealing		potted
mechanical interface		refer to the dimensions on the datasheets
electrical interface		Φ 4.2 mm, 4-conductor shielded, PVC jacket, 0.35 m length
environment protection		IP 65
unit weight	g	~ 170

The listed specifications are subject to change without prior notice.

BCM SENSOR TECHNOLOGIES BVBA

Model 1661(I) Single Point Load Cells



Ordering Information

position (pos.) 1: model									
1661(I): made from aluminum alloy									
pos. 2: capacities									
2 kg 10 kg 3 kg 20 kg 5 kg 30 kg 7 kg									
pos. 3: output sensitivity									
2 mV/V									
pos. 4: non-linearity or accuracy class									
0.02 %fs									
pos. 5: bridge resistance									
350 Ω (R _{in} = 410±10Ω, R _{out} = 350±10 Ω)									
pos. 6: threads (live end/fixed end)									
2xM3/2xM3 : two M6 threads at the live end, two M6 threads at the fixed end									
pos. 7: electrical interface									
cable, code = diameter(Φ)/number of conductors/cable jacket/cable length 4.2/4/PVC/0.35 = Φ4.2 mm, 4-conductors shielded, PVC, length = 0.35* m									
pos. 8: environment protection									
IP 65									
pos. 9: accessories for installation									
NA**. In case of "NA", pos.9 can be omitted.									
pos. 10: customized spec's									
When any customized spec's are required, the customer needs to add "C" as the last parameter in the ordering code, and specifies the wished spec's on his order clearly. The customized spec's needs to be confirmed in advance by BCM's sales representative. Code "C" can be omitted if no customized spec's are required.									
pos.1	pos. 2	pos. 3	pos. 4	pos. 5	pos. 6	pos. 7	pos. 8	pos. 9	pos. 10

*: This value can also be a customized value.

** : NA = not available or not applicable

example: 1661(I)-10kg-2mV/V-0.02%fs-350Ω-2xM6/2xM6-4.2/4/PVC/0.35-IP65-C



BCM SENSOR TECHNOLOGIES BVBA

ISO9001 Certified Company