

Model 166H/169H Single Point Load Cells

Features

- parallel bending beam
- low profile
- capacity: 0.3, ..., 70 kg(166H); 20, ..., 200 kg (169H)
- accuracy: 0.05 %fs
- recommended platform size: 120 X 120 mm
- aluminum construction with surface anodized (166H)
17-4PH construction (169H)
- environment protection class: IP 65



Applications

- kitchen scales
- postage scales
- portable scales

Description

The "single point" load cells are made of parallel bending beam working principle. Only one unit is sufficient to build up a scale. These load cells are moment insensitive. That is, when installed in a platform scale, it reads the same regardless of the position of the load applied to the upper platform.

Model 166H/169H load cells are designed to this "single point" type. 166H load cells are manufactured from high quality aluminum alloy of aviation standard, while 169H load cells are made from 17-4PH stainless steel. 166H/169H load cells can be regarded as the longer version of 166G/169G and can measure loads ranging from 0.3 kg to 200 kg with the measuring accuracy of 0.05%fs (fs = full scale).

166H/169H load cells are widely used to manufacture postage scales, kitchen scales, portable scales and other platform scales.

Dimensions

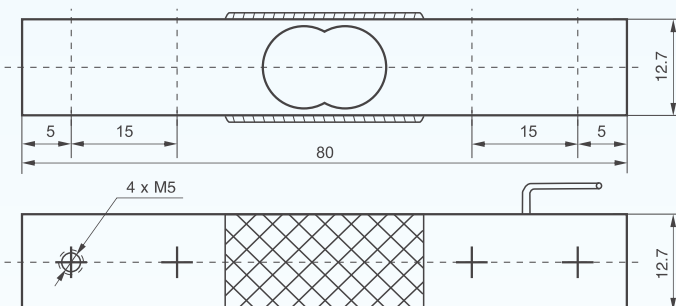

Electrical connection

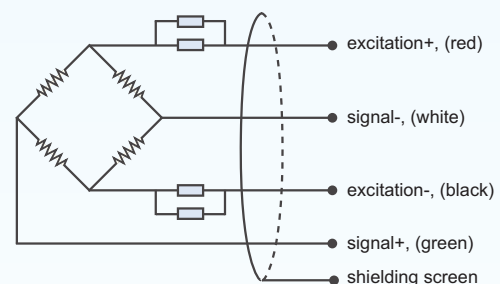

Model 166H/169H Single Point Load Cells



Technical Data

parameters	units	specifications	
model		166H	169H
capacity	kg	0.3, 0.5, 0.7, 1, 3, 5, 7, 10, 30, 50, 70	20, 30, 50, 70, 100, 200
safe load limit	%fs	150	
ultimate overload	%fs	300	200
output sensitivity at full scale	mV/V	1.0 ± 0.1	2.0 ± 0.2
zero unbalance	%fso	± 5	± 1.5
non-linearity	%fs	± 0.05	
hysteresis	%fs	± 0.05	
repeatability	%fs	± 0.03	
creep error (30 min.)	%fs	± 0.05	
excitation (supply voltage)	Vdc	5, ..., 10	
max. excitation voltage	Vdc	15	
input resistance	Ω	1060 ± 50 (standard), 410 ± 30	
output resistance	Ω	1000 ± 50 (standard), 350 ± 10	
insulation resistance	MΩ	≥ 2000@50 Vdc	
storage temp. range	°C	-35 ~ +80	
operating temp. range	°C	-20 ~ +60	
compensated temp. range	°C	-10 ~ +50	
temp. coefficient of sensitivity	%fs/°C	± 0.01	
temp. coefficient of zero	%fs/°C	± 0.01	
load cell body material		aluminum alloy	17-4PH stainless steel
sealing		potted	
mechanical interface		refer to the dimensions on the datasheets	
electrical interface		Φ3.8 mm, 4-conductor shield, PVC jacket, 0.25 m	
environment protection		IP 65	
unit weight	g	~ 35	

The listed specifications are subject to change without prior notice.

BCM SENSOR TECHNOLOGIES BVBA

Model 166H/169H Single Point Load Cells



Ordering Information

position (pos.) 1: model									
166H: made from aluminum alloy					169H: made from 17-4PH stainless steel				
pos. 2: capacities									
for 166H		1 kg	10 kg	for 169H		100 kg			
0.3 kg		2 kg	20 kg	20 kg		200 kg			
0.5 kg		3 kg	30 kg	30 kg					
0.7 kg		5 kg	50 kg	50 kg					
		7 kg	70 kg	70 kg					
pos. 3: output sensitivity									
1 mV/V (for 166H)									
2 mV/V (for 169H)									
pos. 4: non-linearity or accuracy class									
0.05 %fs									
pos. 5: bridge resistance									
1000 Ω (Rin = 1060 Ω, Rout = 1000 Ω)									
350 Ω (Rin = 410 Ω, Rout = 350 Ω)									
pos. 6: threads (live end/fixed end)									
2xM5/2xM5 : two M5 threads at the live end, two M5 threads at the fixed end									
pos. 7: electrical interface									
cable, code = diameter(Φ)/number of conductors/cable jacket/cable length 3.8/4/PVC/0.2 = Φ3.8 mm, 4-conductors shielded, PVC, length = 0.2 m*									
pos. 8: environment protection									
IP 65									
pos. 9: accessories for installation									
NA**. In case of "NA", pos.9 can be omitted.									
pos. 10: customized spec's									
When any customized spec's are required, the customer needs to add "C" as the last parameter in the ordering code, and specifies the wished spec's on his order clearly.									
The customized spec's needs to be confirmed in advance by BCM's sales representative.									
Code "C" can be omitted if no customized spec's are required.									
pos.1	pos. 2	pos. 3	pos. 4	pos. 5	pos. 6	pos. 7	pos. 8	pos. 9	pos. 10

*: This value can also be a customized value.

** : NA = not available or not applicable

example: 166H-10kg-1mV/V-0.05%fs-1000-2xM5/2xM5-3.8/4/PVC/0.2-IP65-C



ISO9001 Certified Company

BCM SENSOR TECHNOLOGIES BVBA

Industriepark Zone 4, Brechtsebaan 2
B-2900 Schoten - Antwerpen, BELGIUM

Tel.: +32-3-238 6469
Fax: +32-3-238 4171

website: www.bcmsensor.com
email: sales@bcmsensor.com