

Model 1912/1992 Static Torque Transducers



Features

- strain gauge technology
- range from 30 Nm to 300 Nm
- accuracy up to 0.1 %fs
- mild steel with nickel plated treatment (1912)
17-4PH construction (1992)
- protection grade IP 65

Applications

- torque wrench and torsion measurement of shaft

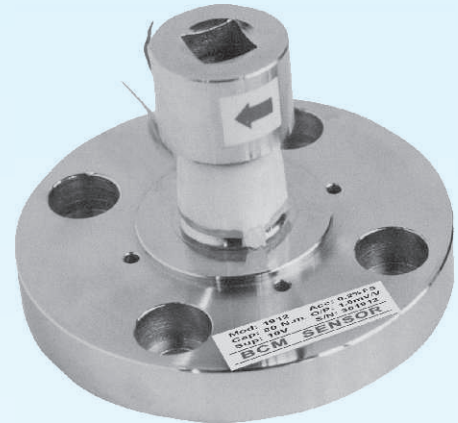

Description

Based on BCM's advanced strain gauge technology, 1912/1992 static torque transducers are made from either alloy steel (1912) or stainless steel (1992) and sealed to IP 65 protection grade. 1912/1992 static torque transducers are operated in the following way: one side of the transducer is fixed as the stationary part, while the other side is as motion part which intends to have torsion shift corresponding to the stationary part. These transducers are designed for symmetric use, i.e., use in measuring torques in both directions: clockwise (positive torque) and anti-clockwise (negative torque).

1912/1992 torque transducers can measure torque ranges from 30 Nm to 300 Nm with an accuracy up to 0.1%fs. On request, these transducers can be supplied as transmitters with conditioned signals such as 0~5 V can be obtained by using an external signal conditioner.

1912/1992 torque transducers are widely used in torque wrench and torsion measurement of shaft.

Dimensions

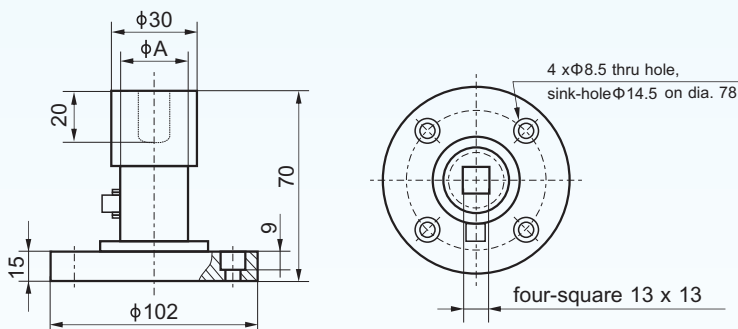

Capacity (N.m.)	30	50	60	80	100	200	300
A	44	44	44	44	44	52	52

Electrical Connection

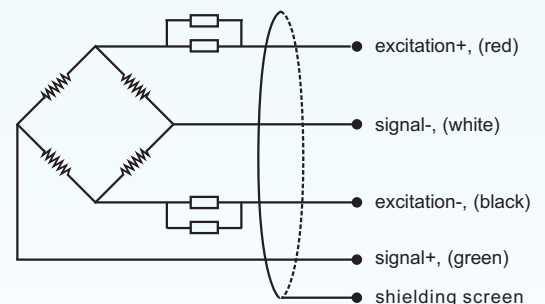

BCM SENSOR TECHNOLOGIES BVBA

Model 1912/1992

Static Torque Transducers



Technical Data

parameters	units	specifications		
measuring range	Nm	30, 50, 70, 100, 200, 300		
safe load limit	%fs	120		
ultimate overload	%fs	150		
output sensitivity at fs	mV/V	2.0 ± 0.2		
zero unbalance	%fso	± 1		
non-linearity	%fs	± 0.1	± 0.2	± 0.3
hysteresis	%fs	± 0.1	± 0.2	± 0.3
repeatability	%fs	± 0.1	± 0.2	± 0.3
error of asymmetry	%fs	± 0.1	± 0.2	± 0.3
excitation (supply voltage)	Vdc	10		
max. excitation voltage	Vdc	15		
input resistance	Ω	390 ± 30 (standard), 740 ± 30		
output resistance	Ω	350 ± 10 (standard), 700 ± 30		
insulation resistance	MΩ	≥ 1000@50 Vdc		
storage temp. range	°C	-35 ~ +80		
operating temp. range	°C	-20 ~ +65		
compensated temp. range	°C	-10 ~ +40		
temp. coefficient of sensitivity	%fs/°C	± 0.01	± 0.02	± 0.03
temp. coefficient of zero	%fs/°C	± 0.01	± 0.02	± 0.03
load cell body material		mild steel (1914), 17-4PH stainless steel (1994)		
sealing		potted		
mechanical interface		refer to the dimensions on the datasheets		
electrical interface		Φ5 mm, 4-conductor shielded cable, PVC jacket, 1 m		
environment protection		IP 65		
unit weight	g	~ 200		

The listed specifications and dimensions are subject to change without prior notice.

*: On request, model 1912/1992 can be supplied as transmitter with conditioned output of 0~5 Vdc.

Since torques in both clockwise and anti-clockwise can be measured, the zero-torque state of the torque transmitters can be set at 0 Vdc or 2.5 Vdc. In case the "zero output" is set to 2.5 Vdc, a asymmetric O/P can be obtained from the transmitter: the full scale O/P of the maximum positive torque will be 5 Vdc while the full scale O/P of the maximum negative torque is 0 Vdc. If the "zero output" is set to 0V, a symmetric O/P will be obtained for positive and negative torques, e.g., the set full scale O/P will be set to ±5 Vdc.



BCM SENSOR TECHNOLOGIES BVBA

ISO9001 Certified Company

Model 1912/1992

Static Torque Transducers



Ordering Information

position (pos.) 1: model									
1912: made from mild steel 1992: made from 17-4PH stainless steel									
pos. 2: capacities									
30 Nm 100 Nm 50 Nm 200 Nm 70 Nm 300 Nm									
pos. 3: output sensitivity									
2 mV/V*									
pos. 4: non-linearity or accuracy class									
0.1 %fs 0.2 %fs (standard) 0.3 %fs									
pos. 5: bridge resistance									
350 Ω (Rin = 390±30 Ω, Rout = 350±10 Ω), standard 700 Ω (Rin = 740±30 Ω, Rout = 700±10 Ω)									
pos. 6: mechanical interface									
Refer to the dimensions on the datasheets. Pos. 6 can be omitted from the ordering code.									
pos. 7: electrical interface									
cable, code = diameter(Φ)/number of conductors/cable jacket/cable length 5/4/PVC/1 = Φ5 mm, 4-conductors shielded, PVC, length = 1**m									
pos. 8: environment protection									
IP 65									
pos. 9: accessories for installation									
N = NA***. In case of "NA", pos.9 can be omitted.									
pos. 10: customized spec's									
When any customized spec's are required, the customer needs to add "C" as the last parameter in the ordering code, and specifies the wished spec's on his order clearly. The customized spec's needs to be confirmed in advance by BCM's sales representative. Code "C" can be omitted if no customized spec's are required.									
pos.1	pos. 2	pos. 3	pos. 4	pos. 5	pos. 6	pos. 7	pos. 8	pos. 9	pos. 10

*: On request, model 1912/1992 can be supplied as transmitter with conditioned output of 0-5 Vdc:
In case the "zero output" is set to 2.5 Vdc, code = 0/5Vasym
In case the "zero output" is set to 0V, code = ±5Vsym

** : This value can also be a customized value.

***: NA = not available or not applicable

example: 1992-100Nm-2mV/V-0.2%fs-350Ω-5/4/PVC/1-IP65-C



BCM SENSOR TECHNOLOGIES BVBA

ISO9001 Certified Company

Industriepark Zone 4, Brechtsebaan 2
B-2900 Schoten - Antwerpen, BELGIUM

Tel.: +32-3-238 6469
Fax: +32-3-238 4171

website: www.bcmsensor.com
email: sales@bcmsensor.com