

Model 215T Heavy Duty Pressure Transmitters

Based on ceramic capacitive and piezoresistive technology, model 215T pressure transmitters are designed for automation processes control in oil and gas industries. These transmitters are certified to be explosive proof (Exia II CT6). The diaphragm and wetted parts of 215T pressure transmitters are made from materials which allow corrosive media to be measured. For different field applications, the process connection can be configured in form of inner cavity type (type I), semi-flush membrane type (type II), flange type (type III), isolating diaphragm type (IV) or fast screw-in type (V). Type I, IV and V are used for gases or dilute liquids, while type II and type III can be used to measure viscous fluids or fluids with grains.

Model 215T pressure transmitters have a wide pressure range for gauge pressure measurement, which spans from 0~10 mbar to 0~600 bar. While the range for absolute pressure measurement spans from 40 mbar to 20 bar. The output signal of 215T is 4~20 mA with HART protocol. These transmitters are also equipped with a 4½ digits LCD display. The measuring accuracy of 215T transmitter is up to 0.2 %fso (fso = full scale output). The medium temperature range is -40 ~ +125 °C.



Features:

- pressure ranges & type: 0~10 mbar, ..., 0~600 bar, gauge (G)
- 40 mbar, ..., 20 bar, absolute (A)
- output signal: 4~20 mA with HART protocol
- accuracy: 0.2 %fso, 0.5 %fso (standard)
- medium temperature range: -40 ~ +125 °C
- material of pressure membrane: ceramic (Al2O3)
- material of wetted parts: 316LSS (standard), option: Hastelloy-C
- housing material: aluminum alloy
- explosive-proof: Exia II CT6
- protection class: IP 65



215T (type I):
inner cavity type



215T (type II):
semi-flush membrane type



215T (type III):
flange type



215T (type IV):
isolating
diaphragm type



215T (type V):
fast screw-in type

Dimensions:

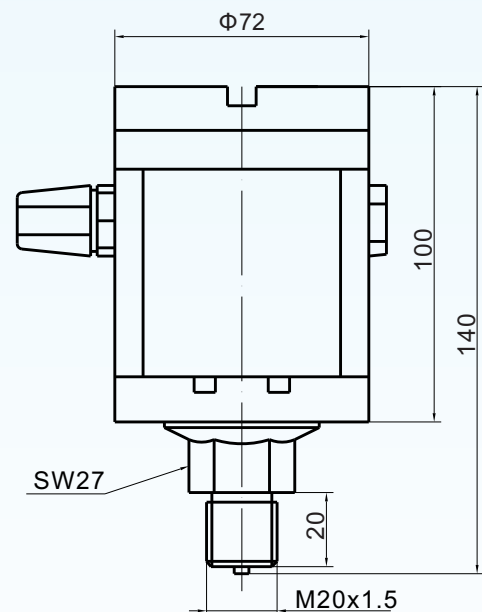

BCM SENSOR TECHNOLOGIES BVBA

Model 215T Heavy Duty Pressure Transmitters

Electrical connection:

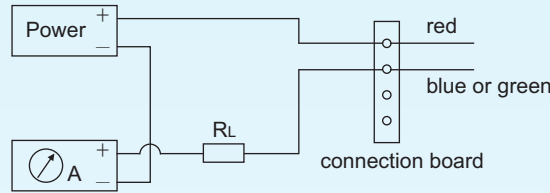

Specifications:

parameters	units	specifications	
pressure media	type II, III	viscous fluids or fluids with grains (compatible with the material of the wetted parts)	
	type I, IV, V	gases or dilute liquids (compatible with the material of the wetted parts)	
measuring ranges	gauge (G*)	mbar	0~10, 0~20, 0~70, 0~100, 0~200, 0~350, 0~700
		bar	0~1, 0~2, 0~3.5, 0~7, 0~10, 0~20, 0~35, 0~70, 0~100, 0~200, 0~350, 0~600
	absolute (A)	mbar	0~40, 0~70, 0~100, 0~200, 0~350, 0~700
		bar	0~1, 0~2, 0~3.5, 0~7, 0~10, 0~20
overload pressure		2 bar (for range ≤1 bar), 200 %FS (for range >1 bar)	
output signal	mA	4~20 mA with HART protocol	
power supply	V	12, ..., 36 (depending on the load resistance)	
accuracy	%FSO	± 0.2, ± 0.5 (standard)	
long term stability	%FSO/year	± 0.15	
life time	cycle	10 ⁸	
response time	ms	<2	
load resistance	Ω	250 ~ 1150	
storage temperature range	°C	-40 ~ +85	
operating temperature range	°C	-40 ~ +125	
compensated temperature range	°C	0 ~ +70	
temperature coefficient of SPAN	%FSO/°C	± 0.01	
temperature coefficient of ZERO	%FSO/°C	± 0.01	
process connection & material	type I, II	M20x1.5 (standard), 1/2 NPT, G1/2	
	type III, IV, V	flange (type III); isolating diaphragm (type IV); fast screw-in (type V)	
	material	316L SS, option: Hastelloy-C	
electrical connection	inner thread	M20x1.5 (standard), 1/2 NPT	
housing material		aluminum alloy	
environment protection	IP rating	IP 65	
explosive-proof	proof rating	Exia II CT6	
field display		4 ½ LCD digital display	
net weight	kg	0.9	

The listed specifications are subject to change without prior notice.

*: On request, 215T is available for negative pressure measurement in gauge pressure. The negative pressure range is half of the positive pressure range, but not beyond -1 bar. For example, if the pressure range of the concerned 215T is 0~700 mbarG and this 215T is to be used for negative pressure measurement, then the customer needs to specify the pressure range as (-350/+700)mbarG.

How to order: model - range & type - output - accuracy - process connection (& material) - electrical connection - customer specific requests (if any)

ordering code: example: 215T(I) - (-1/+3.5) barG - 4/20 mA with HART - 0.5%fso - G1/2 (316L) - M20x1.5



BCM SENSOR TECHNOLOGIES BVBA

ISO9001 Certified Company