

Model 451S/459S Double-ended Shear Beam Load Cells

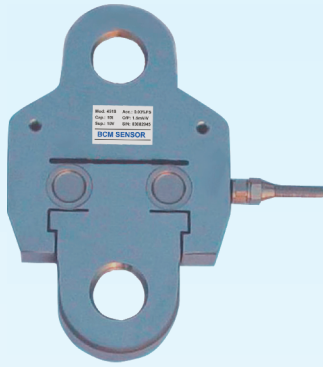

type: double-ended shear beam load cell
material: alloy steel (451S) / stainless steel (459S)
surface: nickel plated treatment (451S only)
protection: IP 66
application: hanging scales and hopper scales

Dimensions:

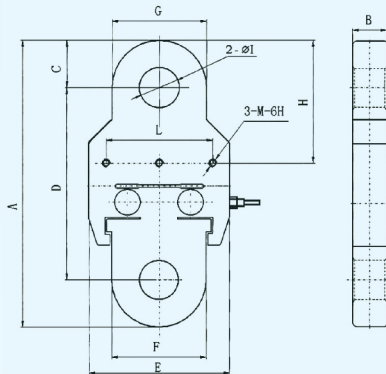

Electrical connection:

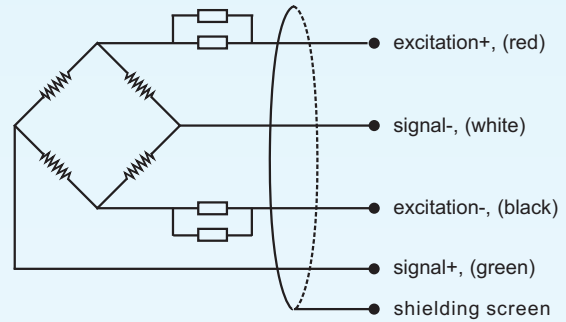

	A	B	C	D	E	F	G	H	I	M	L
1T-2T	189	20	31	127	110	62	62	84	Ø24	M8	87
3T-5T	243	30	40	163	120	80	80	104	Ø33	M8	87
10T	322	43	45	232	140	90	90	125	Ø40	M8	87
20T-30T	395	50	75	245	205	150	150	170	Ø60	M8	175

Specifications:

parameters	units	specifications	
capacity	t	1, 2, 3, 5, 10, 20, 30	
rated output	mV/V	1.5 ± 0.1	2.0 ± 0.1
accuracy	%FSO	± 0.03	± 0.05
non-linearity	%FSO	± 0.03	± 0.05
hysteresis	%FSO	± 0.03	± 0.05
repeatability	%FSO	± 0.02	± 0.02
creep	%FSO/30min	± 0.02	± 0.05
temperature coefficient of SPAN	%FSO/10°C	0.02	0.02
temperature coefficient of ZERO	%FSO/10°C	0.03	0.05
zero unbalance	%FSO	1.0	
input resistance	Ω	780 ± 10	
output resistance	Ω	700 ± 10	
insulation resistance	M	≥5000@50 VDC	
excitation recommended	Vdc	10	
maximum excitation	Vdc	18	
compensated temperature range	°C	-10 ~ +55	
operating temperature range	°C	-35 ~ +80	
safe overload	%FS	150	
ultimate overload	%FS	200	
cable length	m, shielded PVC cable	6 (Φ5.7 mm wireε-)	

The listed specifications are subject to change without prior notice.

How to order: model - capacity - output - accuracy - IP rating - cable length
 - customer specific requests

ordering code example: 451S - 30t - 2mV/V - 0.05%fso - IP 67 - 6m - no specific requests

BCM SENSOR TECHNOLOGIES BVBA



ISO9001 Certified Company