

# Model MPT160

## Melt Pressure Transducers & Transmitters



BCM melt pressure transducers and transmitters (MPT) are developed from BCM strain gauge technology and manufactured in mass production. The MPT are constructed with a full bridge strain gauge circuit and 100% made from stainless steel material (standard version). In addition, the pressure diaphragm features a surface treatment with special alloy coating for all the MPT models. Both the rigid stem and flexible extension provide thermal isolation to MPTs electronic circuitry, which enable MPT suitable for melt pressure and melt temperature measurements.

MPT160-series are basic models of BCM MPT, from which the other models are developed. The output of BCM MPT is either the strain gauge signal (for instance, 3.33mV/V multiplied by the bridge excitation voltage), or the amplified signals (such as 0~10 Vdc or 4~20 mA). By short-circuit, a shunt resistor will be connected which provides MPT with a 80%fso signal for calibration without need of the external calibration pressure.

### Features:

- \* wide measuring range from 0~10 bar to 0~2000 bar;
- \* higher measuring accuracy up to 0.3%fso;
- \* internal shunt calibration signal of 80%fso;
- \* amplified output signal available with Zero and Span adjustment;
- \* 100% stainless steel construction with special alloy coating
- \* on pressure diaphragm;
- \* hastelloy-C diaphragm available on request.

### Electrical Connectors:

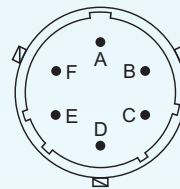

6-pin male connector  
Y LH25N1006J-4  
(6-hole mating socket: Y LH26N1006K22)

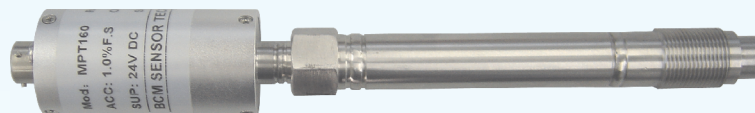

### Dimensions:

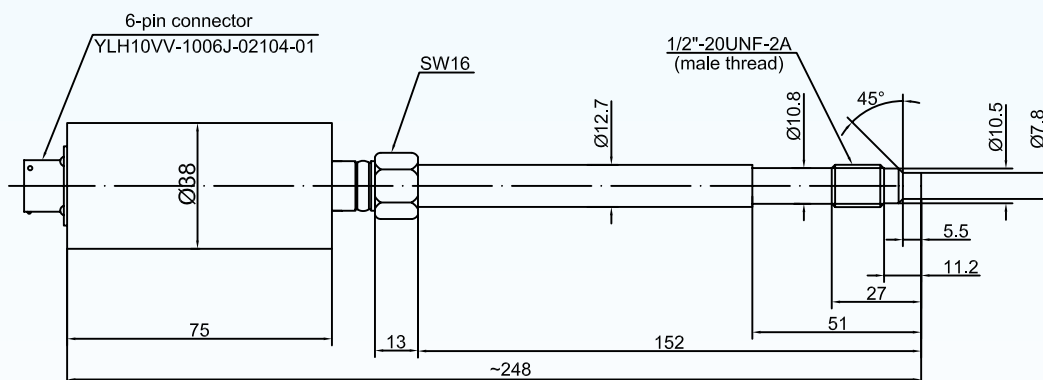

## BCM SENSOR TECHNOLOGIES BVBA

# Model MPT160

## Melt Pressure Transducers & Transmitters



### Specifications:

parameters	units	specifications
measuring range	bar	0/10, 0/20, 0/35, 0/50, 0/70, 0/100, 0/200, 0/350, 0/500, 0/700, 0/1000, 0/1400, 0/2000
overload pressure	% FS	150 (2100 bar max.)
signal output @ FS	mV/V	3.33
or: amplified output signal		0~5 Vdc, 0~10 Vdc, 4~20 mA
supply voltage	Vdc	10 (8~12 acceptable) for MPT of 3.33 mV/V strain gauge output 12~36 for MPT of amplified output signal
combined error	%fso	0.3, 0.5 (standard), 1.0
zero adjustment	%fso	±10
span adjustment	%fso	± 6
repeatability	%fso	0.2
output resistance	Ω	350 ± 10%
insulation resistance	MΩ	≥ 500 @ 100 Vdc
max. temp. @ wetted parts	°C	400
temperature coefficient of ZERO	%fso/10°C	0.5
temperature coefficient of SPAN	%fso/10°C	0.5
long term stability	%fso/year	< 0.15
compensated temp. range	°C	0~80
process connection	external thread	1/2"-20 UNF-2A (standard), M14x1.5, M18x1.5
electrical connection	connector	6-pin (standard) male tighten connector, 8-pin male screw in connector
max. mounting torque	N.m.	40
weight	kg	0.5

The listed specifications are subject to change without prior notice.



**BCM SENSOR TECHNOLOGIES BVBA**

ISO9001 Certified Company

# Model MPT160

## Melt Pressure Transducers & Transmitters



### Ordering codes:

example: MPT160 - 700 - D - II - M - d - X

model	
MPT160	MPT260*
MPT161	MPT261*
MPT162	MPT262*
MPT163	MPT263*

pressure ranges	
010 = 0~10 bar	350 = 0~350 bar
020 = 0~20 bar	500 = 0~500 bar
035 = 0~35 bar	700 = 0~700 bar
050 = 0~50 bar	1000 = 0~1000 bar
070 = 0~70 bar	1400 = 0~1400 bar
100 = 0~100 bar	2000 = 0~2000 bar
200 = 0~200 bar	

output signal	
A = 3.33 mV/V	C = 0~10 V (4-wire)
B = 0~5 V (4-wire)	D = 4~20 mA (2-wire)

combined error
I = $\pm 0.3$ %fso
II = $\pm 0.5$ %fso (standard)
III = $\pm 1.0$ %fso

process connection
M = 1/2"-20 UNF-2A (standard)
N = M14 x 1.5
O = M18 x 1.5

length of rigid stem	
a = 76 mm	d = 228 mm
b = 102 mm	e = 305 mm
c = 152 mm (standard)	f = other length

electrical connection
X = 6-pin male connector (standard)
Y = 8-pin male connector
Z = others

\* : MPT26X-series feature a pressure manometer mounted on the top of MPT16X-series products.

ordering code example: MPT160 - 700 - D - II - M - d - X

MPT160 melt pressure transducer with measuring range 0~700 bar, output 4 ~ 20 mA, combined error 0.5 %FS, connection thread 1/2"-20UNF-2A, rigid stem length 228 mm, and 6-pin male electrical connector.

### OPTIONS

1. MPT with CANbus output is available on request.
2. The 6-core (for 3.33mV/V, 0~5 V or 0~10 V output) or 4-core (for 4~20 mA output), shield VPC cable of 5 meter length, with a 6-hole or 8-hole mating socket connected, is available on request.
3. The 2-core temperature compensation cable of 5 meter length with a 2-hole mating socket connected, is available on request.



**BCM SENSOR TECHNOLOGIES BVBA**

ISO9001 Certified Company

Industriepark Zone 4, Brechtsebaan 2  
B-2900 Schoten - Antwerpen, BELGIUM

Tel.: +32-3-238 6469  
Fax: +32-3-238 4171

website: [www.bcmsensor.com](http://www.bcmsensor.com)  
email: [sales@bcmsensor.com](mailto:sales@bcmsensor.com)