

High-capacity load cell

for nominal loads of 7.5 t to 300 t



Description

The model series F1270 load cell is available with nominal loads of 7.5t to 300t and has been specially developed for deployment in container and silo weighing systems.

This pressure and force transducer is ideally suited for harsh industrial applications and for use in the construction of testing and manufacturing systems, where robustness and long-term stability are the main requirements.

The use of stainless steel, the welded cover of the DMS measuring elements and the used of a glass leadthrough for the cable connection allow the equipment to be used without problems, even under unfavourable environmental conditions.

The integrated radii of the load transducers allow the equipment to be installed using simple force introduction components.

The special calibration (in $mV/V/\Omega$) means that tangential calibration of the scale is not usually required.

Special features

- Extremely accurate.
- Stainless steel load cell.
- Hermetically sealed.
- Protection class IP 68.
- High input resistance: 1100 Ω .
- Calibration in $mV/V/\Omega$.
- Cables are easy to replace.
- A full range of installation kits is available.

Options

- Integrated over voltage suppressors (4x)

Measuring ranges

- 7.5 ... 300 t

Applications

- Weighing, dosing equipment, silo weighing operations
- Production lines
- Testing and manufacturing plants

Specific information

- Completely air tight; cable connection with the help of a glass bushing

Model: F1270

Technical data

Model series	F1270	Option
Nominal load F_{nom}	7.5 / 15 / 22.5 / 30 / 40 / 50 / 100 / 150 / 300 t	
Limit load	200% F_{nom}	
Breaking load	> 300% F_{nom}	
Calibration in mV/V/Ω (A...I classified)	≤± 0.05% of F.S.	≤± 0.005% of F.S.
Combined error	≤± 0.04% of F.S. (7,5 – 300 t)	≤± 0.02% of F.S. (7,5 – 50 t)
Creep 30 min. at F_{nom}	≤± 0.06% of F.S.	≤± 0.016% of F.S.
Nominal temperature range	-10 ... +40°C	
Service temperature range	-40 ... +80°C	
Temperature effect - span - zero	≤± 0.02% of F.S. / 10 K ≤± 0.04% of F.S. / 10 K	≤± 0.01% of F.S./ 10 K ≤± 0.009% of F.S./10 K
Protection type (acc. to EN 60 529/IEC 529)	IP 68	
Insulation resistance	> 5 GΩ / 100 V	
Analogue output - Output signal - Bridge resistance - Tolerance of span - Zero - Excitation voltage - Electrical connection	2 mV/V Input: 1150±50Ω Output: 1000±2Ω ≤± 0.1% of F.S. ≤± 5% of F.S. 5 ... 15 V DC Cable, 4-wire, shielded	
Encapsulation	fully hermetically sealed; cable connected using glass lead through	
Material of measuring device	Stainless steel 17-4 PH (1.4548)	

Dimensions

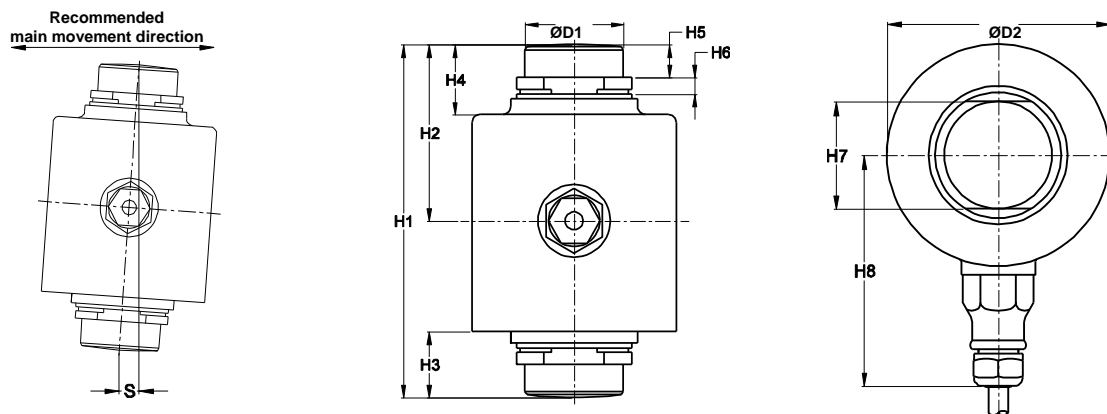

Nominal load	H1	H2	H3	H4	H5	H6	H7	H8	D1	D2	S_{max}^*	RF**
7.5 t	89	44	17	23	11	6	28	75	28	69	8	11 kN
15 t	89	44	17	23	11	6	28	75	28	69	7	20 kN
22.5 t	89	44	17	23	11	6	28	75	28	69	4,5	30 kN
30 t	140	70	26	28	13	6,5	39	84	39	81	10,5	34 kN
40 t	150	75	31	33	13	11,7	39	84	39	81	10	37 kN
50 t	178	89	32	34	17	8,5	44	94	44	99	9	51 kN
100 t	178	89	38,5	38,5	17	12	62	93,8	62	141,3	11,5	152 kN
150 t	210	105	42,7	42,7	20,6	12,8	76,2	121,5	76,2	165,1	14,5	240 kN
300 t	280	140	55,9	55,9	25	21,5	100	121,5	100	165,1	15	468 kN

* S_{max} = Maximum permitted horizontal shift of load introduction.
Recommended shock absorber gap is 2 to 3 mm for 7.5 to 22.5 t, and 3 to 5 mm for 30 to 300 t.

** RF = Return force at S_{max} and E_{max} .

Dimensions in mm; right reserved to make technical changes

Cable connection

- o The load cell has a 4-wire, shielded cable
(AWG 24 for 7.5 to 22.5 t / AWG 20 for 30 to 300 t).
Polyurethane cable sheath.
- o Cable length: 12 m for 7.5 to 22.5 t,
 18 m for 30 to 300 t.
- o Cable diameter: 5 mm for 7.5 to 22.5 t,
 7.8 mm for 30 to 300 t
- o Shield is not attached at load cell end
(shield attached on request).

Electrical connection	Colour
Supply (-)	black
Supply (+)	green
Signal (+)	white
Signal (-)	red
screen	yellow