

## Analogue amplifier for board or top hat rail mounting

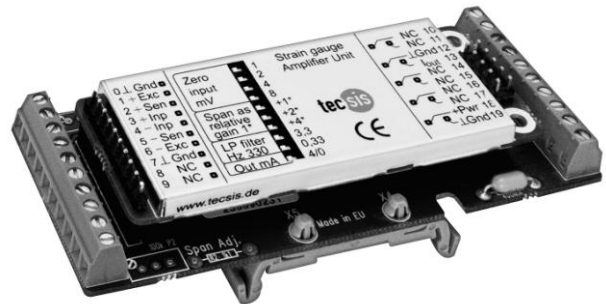

### Description

Analogue measurement amplifiers are used to condition the output signal of strain gauge force transducers to displays or a connected control system. The analogue output of 0(4)...20 mA enables direct signal processing in the SPS control system.

The amplifier can be plugged into an integrated plug strip on a printed circuit board. An optional adaptor board for top hat assembly as specified in DIN EN 50022 can be supplied for fitting in a control cubicle\*. Any strain gauge force transducers which can be driven with direct current can be connected. The measuring range and a possible pre-load (Tara) can be calibrated on site by a DIP switch. A finely trimmed signal is generally not necessary for the SPS controls. If required, however, the adaptor board can be supplied with potentiometers for fine trimming. Interference signals can be reduced with the input low pass filter.

The supply voltage of more than 12 up to 24 Volt guarantees a direct connection to an SPS control system, since this generally has a 24 Volt supply system.

\* An optional adaptor board for top hat assembly must be specially ordered at extra charge

### Features

- Output current 0/4 ... 20 mA
- Optional: Output voltage 10 V across 500  $\Omega$  resistance on the adapter board
- Active low-pass filtering from 0.33 Hz to 33 Hz
- All strain gauge sensors can be connected from 350  $\Omega$  to 7000  $\Omega$
- Zero point and amplification can be set via microswitches
- Optional: Adapter board for mounting on top hat rail

### Applications

- Industrial weighing technology
- Force measurement in automation systems
- Force monitoring on machines

**Model: EZE10X006**

## Technical data

Model	EZE10X006	
Output	<ul style="list-style-type: none"> <li>- Signal</li> <li>- Option</li> <li>- Accuracy</li> <li>- Burden</li> </ul>	0/4 ... 20 mA 0 ... 10 V 0.01 % Output voltage: > 500Ω Output current: < 500Ω
Input	<ul style="list-style-type: none"> <li>- Signal</li> <li>- Sensor supply</li> <li>- Limit frequency</li> </ul>	-2 ... 0 ... 23 mV; 4-wire; 10 VDC, max. 30 mA 0.33, 3.3; 33 Hz, selectable
Setting	<ul style="list-style-type: none"> <li>- Zero point</li> <li>- Amplification</li> </ul>	±65%, from 0 mV to +15mV in 1-mV-steps for 0 or 4 mA output signal; in case of adapter board with potentiometers, continuous adjustment in 8 steps: 1 = ±20 mV Input / 20 mA Output to 8 = ±2.5 mV Input / 20 mA Output; in case of adapter board with potentiometers, continuous adjustment
Power requirement	12 ... 24 VDC, <80 mA, not electrolytically isolated	
Nominal temperature range	-10°C ... +40°C	
Service temperature range	-10°C ... +40°C	
Storage temperature range	-20°C ... +50°C	
Temperature effect	<ul style="list-style-type: none"> <li>- Zero point</li> <li>- Measuring span</li> </ul>	0.05% / 10 K 0.05% / 10 K
Noise emission	acc. to EN 61326	
Noise immunity	acc. to EN 61326	
Protection type (acc. to EN 60 529/IEC 529)	IP 40 (additional housing IP 65 upon request)	
Electrical connection	Terminal block, screw terminals (adapter board)	
Housing	<ul style="list-style-type: none"> <li>- Material</li> <li>- Dimensions (W x H x D)</li> </ul>	for board or top hat rail mounting Tin-plated metal 81,3 x 30,6 x 5,6 mm; with adapter board 99 x 41 x 12 mm
Weight	approx. 26 g; with adapter board approx. 50 g	
Weight	approx. 26 g; with adapter board approx. 50 g	
EMC / Certification	CE 73/23/EEC; 93/98/EEC and 89/336/EEC	

## Dimensions

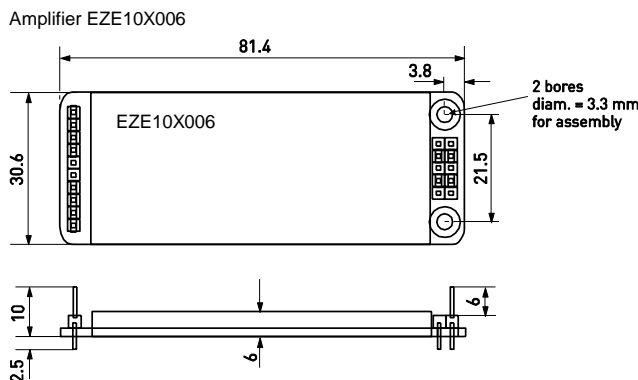
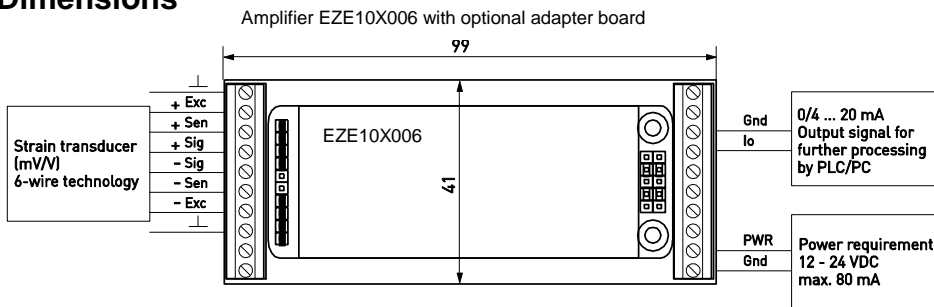

Subject of technical changes