

Tension/compression force transducer with external thread, miniature, for very small measuring ranges



Description

This force transducer is widely used where it is necessary to measure directly in the force line. It is possible, for example, to measure the actual force in ropes and rods.

The force applied to this force transducer is through threaded bolts, which are located on each side of the cylindrical body. The force transducer is made of aluminium for the low measuring range 10N and 20N and in the higher measuring range 50N to 100N out of stainless steel.

Note

To prevent overload, it is advantageous to connect up the transducer electrically during installation and to monitor the measured value.

The force must be applied at the centre and without radial stress.

Features

- Ease of assembly
- Very small design

Measuring ranges

- 10 ..100 N

Applications

- Plant engineering
- Production lines
- Measurement and monitoring facilities
- Special equipment and machinery construction
- Test benches and production lines

Specific information

- Calibration control: 100% signal (option)

Model: F2213

Technical data

Model	F2213		Option
Nominal load F_{nom}	10, 20 N	50, 100 N	
Limit load	150% F_{nom}		
Breaking load	>200% F_{nom}		
Combined error	$\leq \pm 0,16\%$ of F.S.		
Max. dynamic load	$\pm 70\%$ F_{nom} acc. to DIN 50100		
Creep, 30 min. at F_{nom}	$< \pm 0,1\%$ of F.S.		
Nominal deflection	< 0.1 mm		
Nominal temperature range	+5 ... +45°C		
Service temperature range	-10 ... +70°C		
Storage temperature range	-10 ... +70°C		
Reference temperature	23°C		
Temperature effect span	$\leq \pm 0,2\%$ of F.S./10K		
zero	$\leq \pm 0,2\%$ of F.S./10K		
Protection type (acc. to EN 60 529 / IEC 529)	IP 60		
Insulation resistance	> 2 G Ω		
Analogue output	0.5 mV/V		6-pol connection
- Output signal	350 Ω		
- Bridge resistance	Cable integrated amplifier		100% signal
- Option	0 (4) ... 20 mA, 0 ... 10 V DC		
- Tolerance of span	$\leq \pm 15\%$ of F.S.		
- Excitation voltage	2 ... 8 (max. 8 V), 12 ... 28 V DC		
- Electrical connection	for cable integrated amplifier Cable 3 m / 4-wire		
Calibration control			
Material of measuring device	Stainless steel, up to 20 N aluminium		
Gewicht (N)	0,1 kg		
- 10 - 100			

of F.S. = full scale value

When ordering please quote the required measuring range!

Dimensions

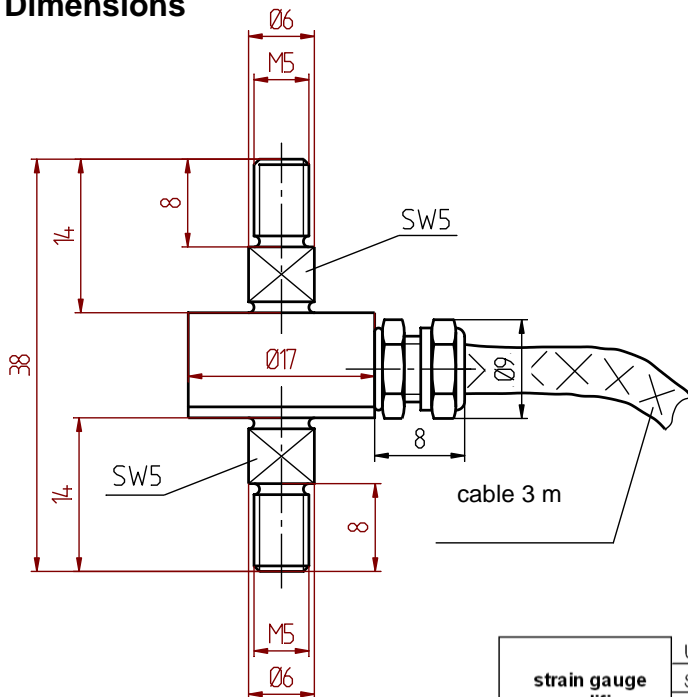

Electrical connection	
Supply. (-)	green
Supply (+)	brown
Sign. (+)	yellow
Sign. (-)	white
Control	grey
Screen	Screen

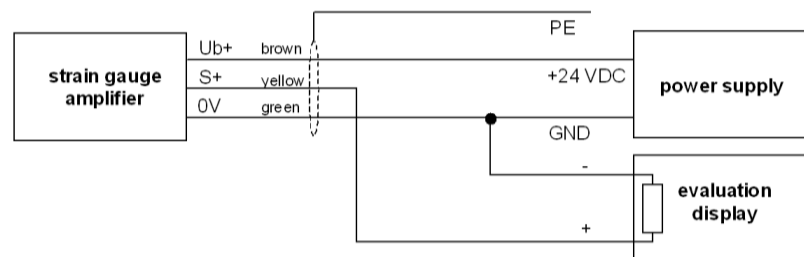

Pin assignment for cable integrated amplifier

Subject to technical changes