

Compression force transducer for measuring of tension forces in parallel clamping tools

Nominal diameter ND20 mm
and ND80 mm



Description

These hydraulic load cells measure and indicate forces directly for a reasonable price. The whole unit (load cell and measuring device) works on the hydraulic principle. Maximum piston stroke is 0.5 mm.

In accordance with the surface area of the piston, the force acting on it is transferred to the hydraulic fluid and from there via the connecting pipe to the measuring instrument.

The straightforward relationship between the pressure, force and piston surface area enables the scale of the measuring instrument to be graduated in a variety of units, e.g. kN, kg, t, m³ or litres.

The piston of this force transmitter is designed to adapt itself to the face of the piston acting on it up to an angle of approx. $\pm 3^\circ$.

For precise conversion of force into pressure the force must act vertically and centred on the piston which must not be subject to lateral forces.

The load cells are unsuited, or suited only to a limited extent, to the measurement of impact or acceleration. Provided that the frequency is not too high, oscillating forces can also be measured with hydraulic load cells. In such case a measuring unit with a rather large working range is advisable in the interests of prolonging service life.

Note

Hydraulic measuring devices are filled with hydraulic fluid in a vacuum environment. For this reason a guarantee of proper functioning is only given on fully assembled units. Sealing glands must not be loosened or removed.

Features

- for compression forces at closers and vices
- Ambient temperature -20 to 60°C
- Stainless steel casing and piston
- Accuracy 1.6% of end scale value when used with pressure measuring instruments class 1.6 and 23°C
- Maximum piston stroke 0.5 mm
- Lateral forces within an angle $\pm 3^\circ$ can be regarded as negligible
- Measurement of axial load and bearing forces in turning and drilling machines as well as extruders
- Operation without power supply

Measuring ranges

- 0.2 kN ... 320 kN

Applications

- Apparatus engineering
- Production lines
- Measuring and test equipment
- Special mechanical engineering applications

Model: F1119, F1136

Technical data

Model	F1119, F1136	Options
Nominal size	ND 20 / ND 80	
Accuracy	+ - 1.6% of end scale value when used with pressure measuring devices class 1.6 and reference temperature 23°C	
Limit load	130% F_{nom}	
Breaking load	> 150 F_{nom}	
Combined error	$\leq \pm 1.6\%$ of F.S.	
Nominal deflection	< 0.5 mm	
Nominal temperature range	-10 ... +50°C	
Protection type	IP 65	
Case	Stainless steel	
Piston	Stainless steel	
Connecting line	-direct connection	-flexible tube, s.s. 1.4571 with 7 mm diameter spiral steel jacket in s.s. 1.4301; maximum lengths = 2 m. -Capillary tube throttle
Pressure measuring device	-Nominal diameter 63 mm in die-cast brass Model P1515, -others on request	-Max.-indicating pointer -Model P1770, diameter 100 mm only not filled -Pressure sensors model P3249
Hydraulic fluid	silicone oil, FFI.-No. 2	
Mounting	Threaded borings in base of casing	
Dimensions	see dimensional drawing	

Measuring range BR F1119 NG 20 [kN]	Pressure range on measuring device in bar BR P1515 resp. BR P3249	Measuring range BR F1136 NG 80 [kN]	Pressure range on measuring device in bar BR P1515 resp. BR P3249	The load cell size indicates the area of the piston in cm ²
0,2	0 ... 1,0	2,0	0 ... 2,5	The measuring device can be supplied with a scale in kN, N, t, kp, kg, m ³ or litres
0,32	0 ... 1,6	3,2	0 ... 4,0	
0,5	0 ... 2,5	6,0	0 ... 8,0	
0,8	0 ... 4,0	8,0	0 ... 10,0	
1,0	0 ... 5,0	12,0	0 ... 16,0	
1,2	0 ... 6,0	16,0	0 ... 20,0	
1,6	0 ... 8,0	20,0	0 ... 25,0	
2,0	0 ... 10,0	32,0	0 ... 40,0	
2,5	0 ... 14,0	40,0	0 ... 50,0	
3,2	0 ... 16,0	50,0	0 ... 60,0	
4,0	0 ... 20,0	80,0	0 ... 100,0	
5,0	0 ... 25,0	120,0	0 ... 160,0	
6,0	0 ... 30,0	160,0	0 ... 200,0	
8,0	0 ... 40,0	200,0	0 ... 250,0	
10,0	0 ... 50,0	250,0	0 ... 315,0	
12,0	0 ... 60,0	320,0	0 ... 400,0	
20,0	0 ... 100,0			
32,0	0 ... 160,0			
50,0	0 ... 250,0			
60,0	0 ... 315,0			

Construction A

Hydraulic force measuring device, consisting of a force transmitter model F1119 ND 20 and pressure gauge model P1515 ND 63.
The piston of this force transmitter is designed to adapt itself to the face of the piston acting on it up to an angle of approx. $\pm 3^\circ$.

Dimensions:

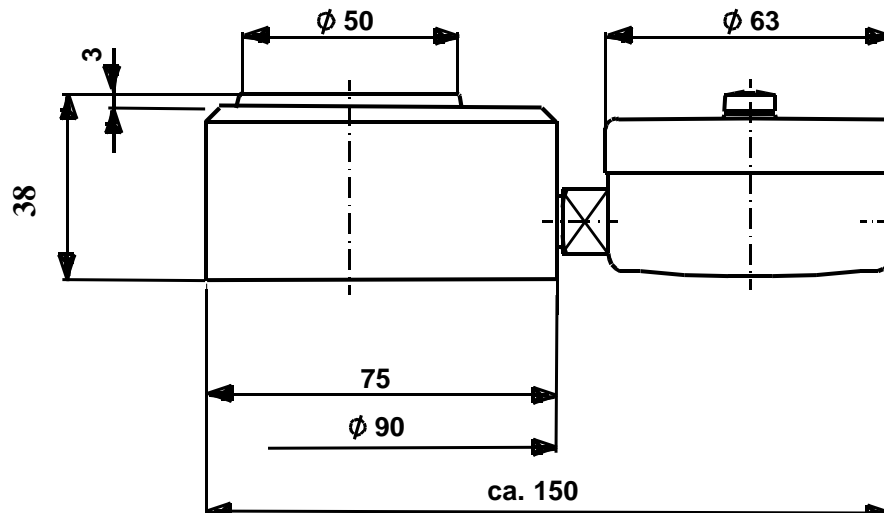

Construction A1

Hydraulic force measuring device, consisting of a force transmitter model F1119 ND 20 and pressure sensor model P3249.
The piston of this force transmitter is designed to adapt itself to the face of the piston acting on it up to an angle of approx. $\pm 3^\circ$.

Dimensions:

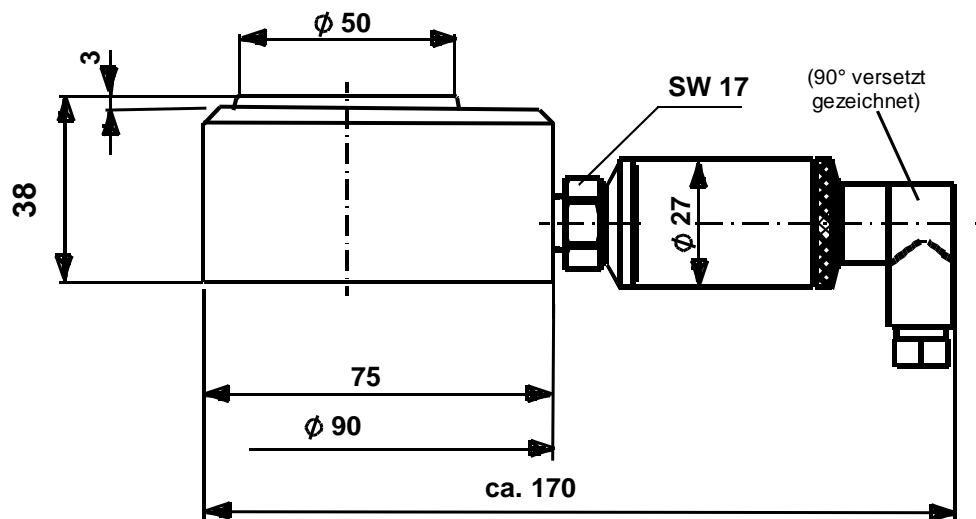

Construction B

Hydraulic force measuring device, consisting of a force transmitter model F1136 ND 80 and pressure gauge model 1515 ND 63.
The piston of this force transmitter is designed to adapt itself to the face of the piston acting on it up to an angle of approx. $\pm 3^\circ$.

Dimensions:

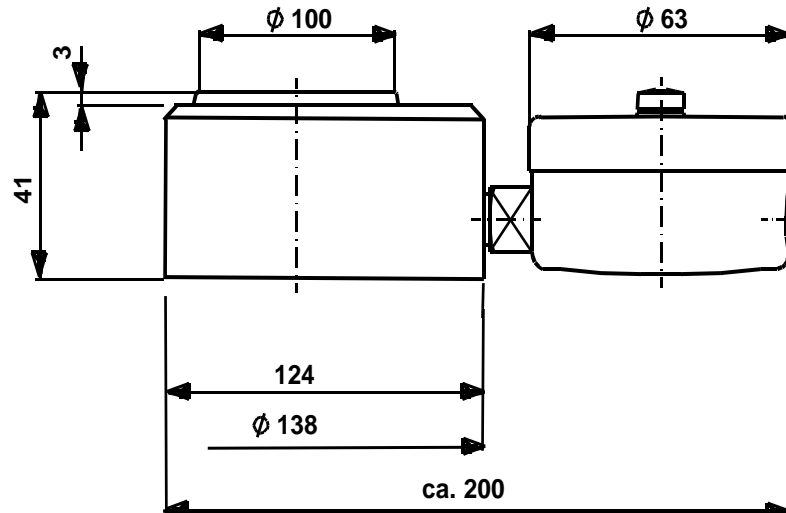

Construction B1

Hydraulic force measuring device, consisting of a force transmitter model F1136 ND 80 and pressure sensor model P3249.
The piston of this force transmitter is designed to adapt itself to the face of the piston acting on it up to an angle of approx. $\pm 3^\circ$.

Dimensions:

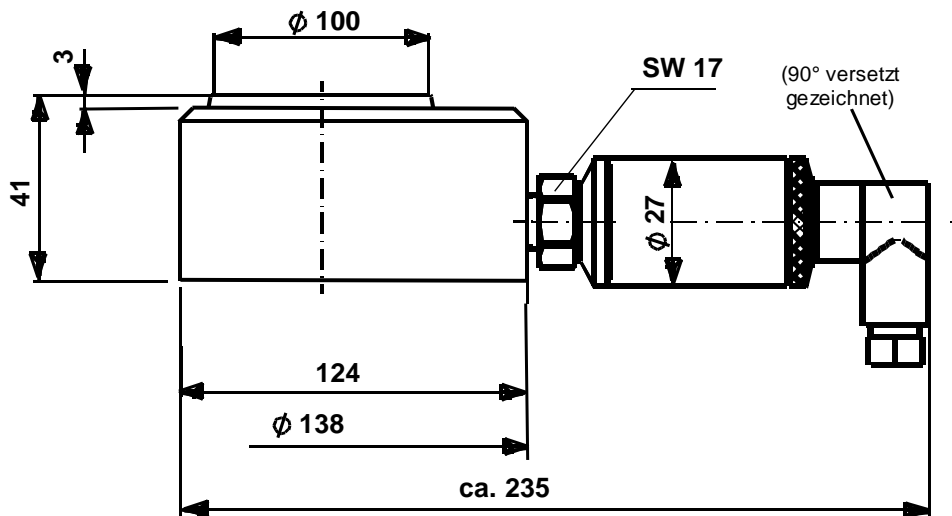

Subject to technical changes