

Tension/compression force transducer with internal thread, S-type

with electrical output



Description

The range of applications for this load cell covers both weighing technology and countless industrial applications where high accuracy, simple installation with a large contact surface and an inexpensive price play a decisive role.

In such conditions, this load cell provides ideal conditions in the measuring ranges from 0...2 kg to 0...5000 kg, and can be used for tension and compression force measurements.

These load cells are splash water protected and function reliably even under difficult service conditions.

Note

In order to avoid overloading, it is advantageous to connect the load cell electrically during installation and to monitor the measured value.

The force to be measured must be applied concentrically and free of transverse force. The load cells are to be mounted on a level surface.

Features

- for tension and compression force measurements
- simple force introduction
- robust design
- simple installation
- Protection class IP 65 or IP 67
- Accuracy 0.1% of fullscale value

Measuring ranges

- 0.02 kN ... 50 kN

Applications

- Plant engineering
- Production lines
- Measurement and monitoring facilities
- Special equipment and machinery construction
- Test benches and production lines

Specific information

- Calibration control: 100% signal (option)
- Load input elements available (option)

Model: F2211

Technical data

Model	F2211		Options
Nominal load in kN kg	0.02, 0.05, 0.1, 0.2, 0.5, 1 2, 5, 10, 20, 50, 100	2, 5, 10, 20, 50 200, 500, 1000, 2000, 5000	
Limit load	150% F_{nom}		
Breaking load	>300% F_{nom}		
Combined error	$\leq \pm 0.2\%$ of F.S.		$\leq \pm 0.1\%$ of F.S. for either tension and compression force
Max. dynamic load	$\pm 70\%$ F_{nom} acc. to DIN 50100		
Creep, 30 min. at F_{nom}	$\leq \pm 0.07\%$ of F.S.		$\leq \pm 0.04\%$ of F.S.
Nominal deflection	< 0.15 mm		
Nominal temperature range	-10 bis +70°C		
Service temperature range	-30 bis +85°C		
Storage temperature range	-50 bis +90°C		
Reference temperature	23°C		
Temperature effect -span -zero	< $\pm 0.12\%$ of F.S./ 10K < $\pm 0.04\%$ of F.S./ 10K		< $\pm 0.08\%$ of F.S./ 10K < $\pm 0.025\%$ of F.S./10K
Protection type (acc. to EN 60529/IEC 529)	IP 65	IP 67	
Insulation resistance	> 2 G Ω		
Insensibility against component forces	60% of nominal value		
Analogue output - Output signal - Bridge resistance - Option - Tolerance of span - Excitation voltage - Electrical connection	2 mV/V (1 mV/V bei 0.02 kN) 350 Ω Cable integrated amplifier 0(4) ... 20 mA, 0 ... 10 V DC $\leq \pm 0.1\%$ of F.S. 2 ... 12 V (max. 15 V), 12 ... 28 V DC for cable integrated amplifier Cable 3 m / 4-wire		
Calibration control			100% signal
Overload protection			for tension- + compression force measurement
Mounting equipment	see sep. data sheet		
Material of measuring device	Aluminium	Stainless steel	
Weight (kN) - 0,02 – 0,05 - 0,1 - 1 - 2 - 5 - 10 - 20 - 50	0,25 kg 0,30 kg 0,57 kg 0,65 kg 1,45 kg 1,5 kg		

of F.S. = full scale value

Dimensions

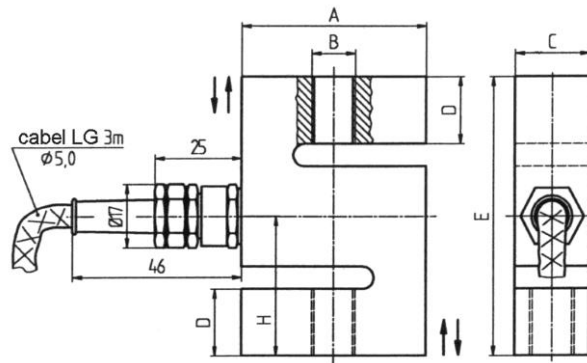

Measuring range [kN]	Dimensions in [mm]					
	A	B	C	D	E	H
0.02, 0.05, 0.1, 0.2, 0.5, 1, 2, 5, 10	50	M 12	20	18	75	37.5
20, 50	65	M 24 x 2	39.5	22	85	42.5

Electr. connection	
Vers. (-)	green
Vers. (+)	brown
Sign. (+)	yellow
Sign.(-)	white
Control	grey
Screen	Screen

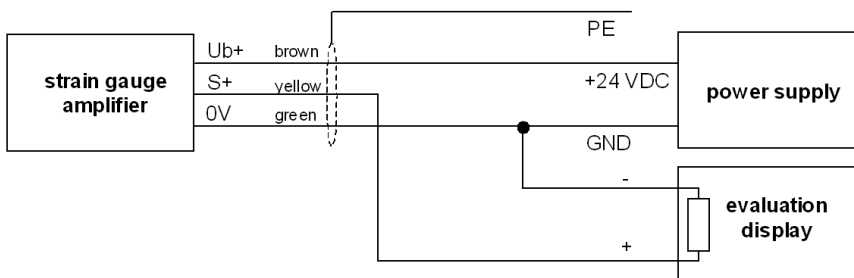

Pin assignment for cable integrated amplifier